

COMUNE DI
FRASSINORO
(PROVINCIA DI MODENA)

REGOLAMENTO EDILIZIO
ESEMPLIFICAZIONI GRAFICHE

Arch. Giuseppe Caruso, Arch. Beatrice Celli, Geom. Mauro Giannotti, Dott. Agr. Giovanni Mondani

Con l'apporto collaborativo
Dell Ufficio Tecnico Comunale
di Frassinoro

2008



Figura 1 - PIANO TERRA O PIANO FUORI TERRA
Art. 2 comma 13



Figura 2 – PIANO SEMINTERRATO
Art. 2 comma 14

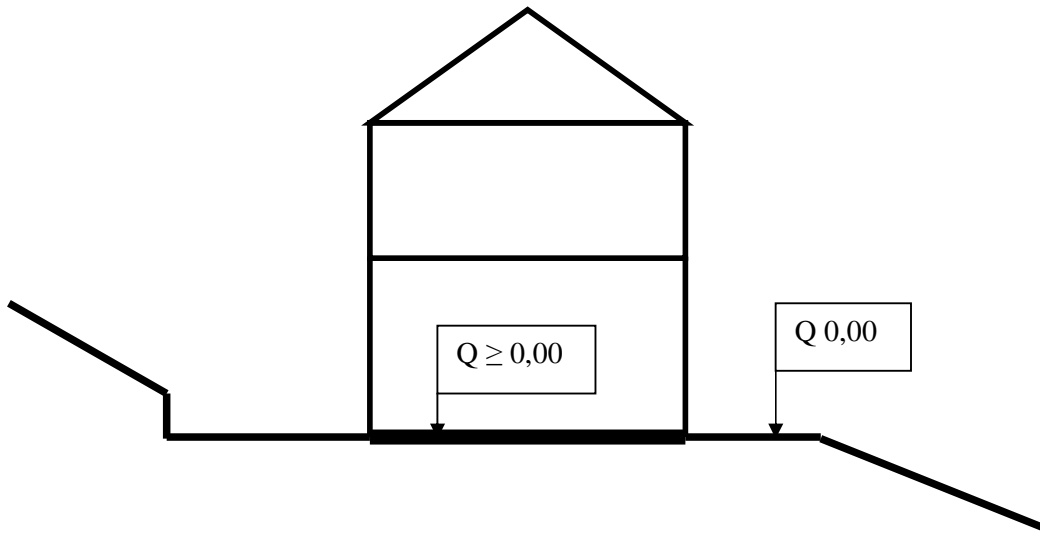

Figura 3 – PIANO INTERRATO
Art. 2 comma 15

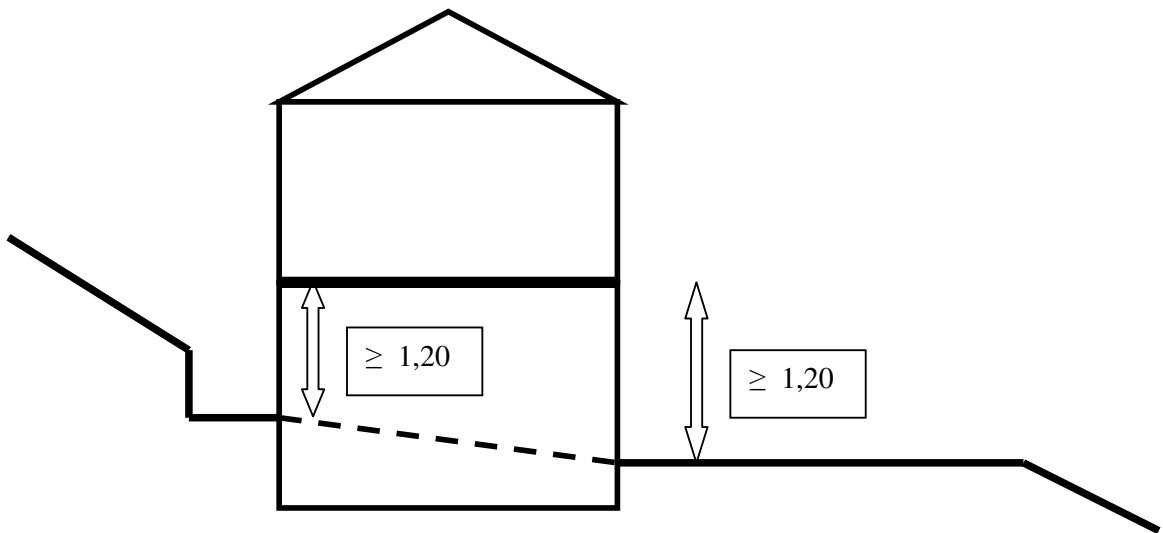

Figura 3 bis – Art. 2 commi 14, 15
L' altezza del tratto A non viene
considerata ai fini della definizione
del piano

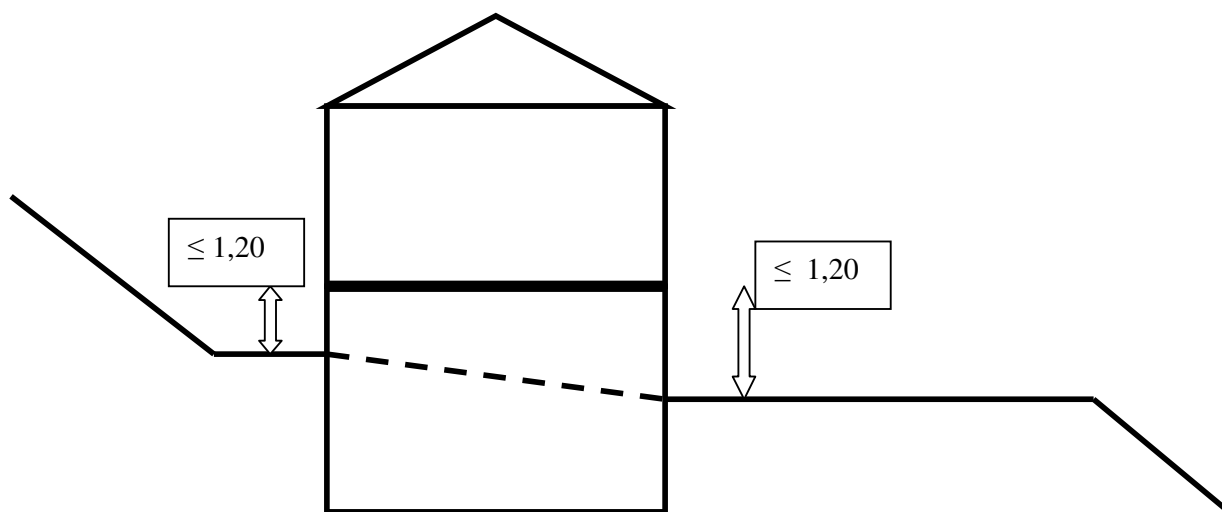

Figura 4 – SOPPALCO – Art. 2 comma 16

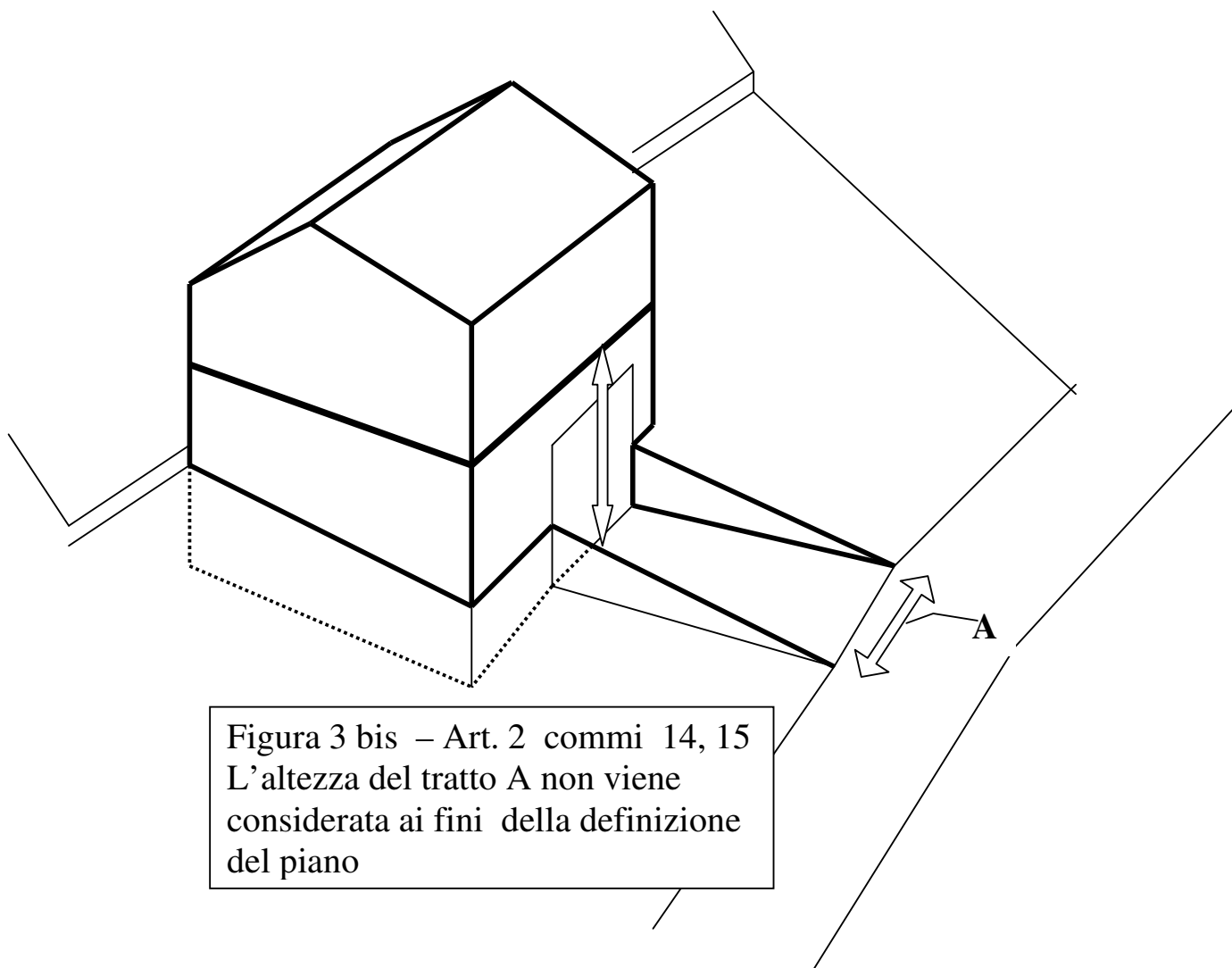

Figura 5 – MODALITA' DI MISURAZIONE DELLE DISTANZE - Art.4 comma 1

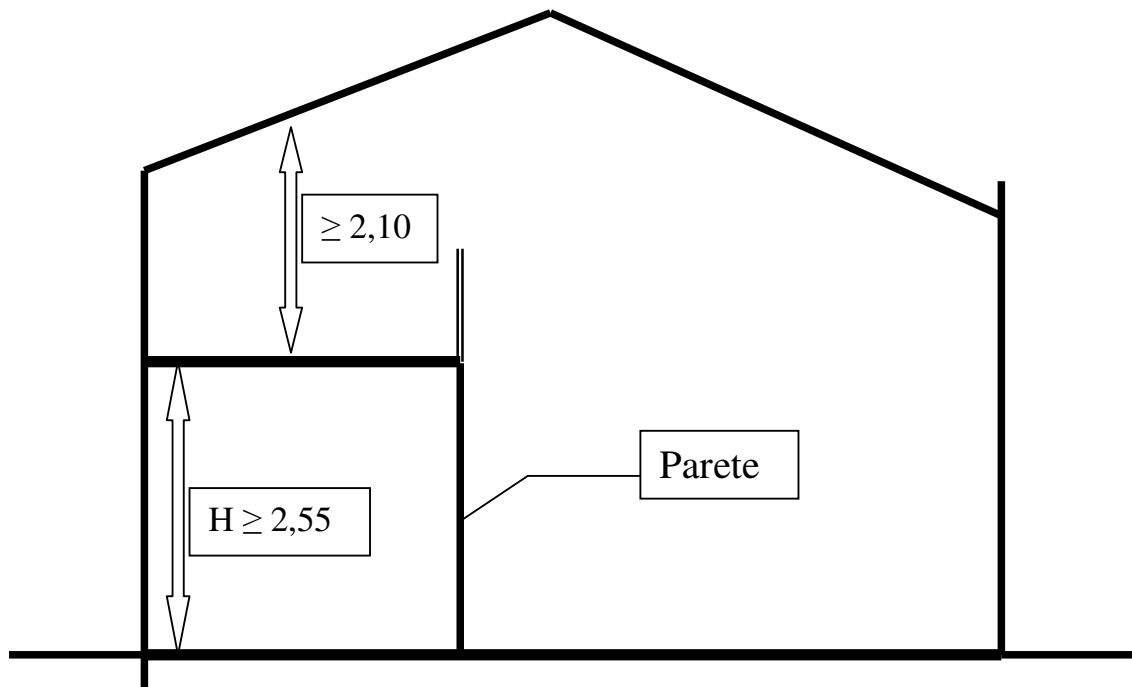
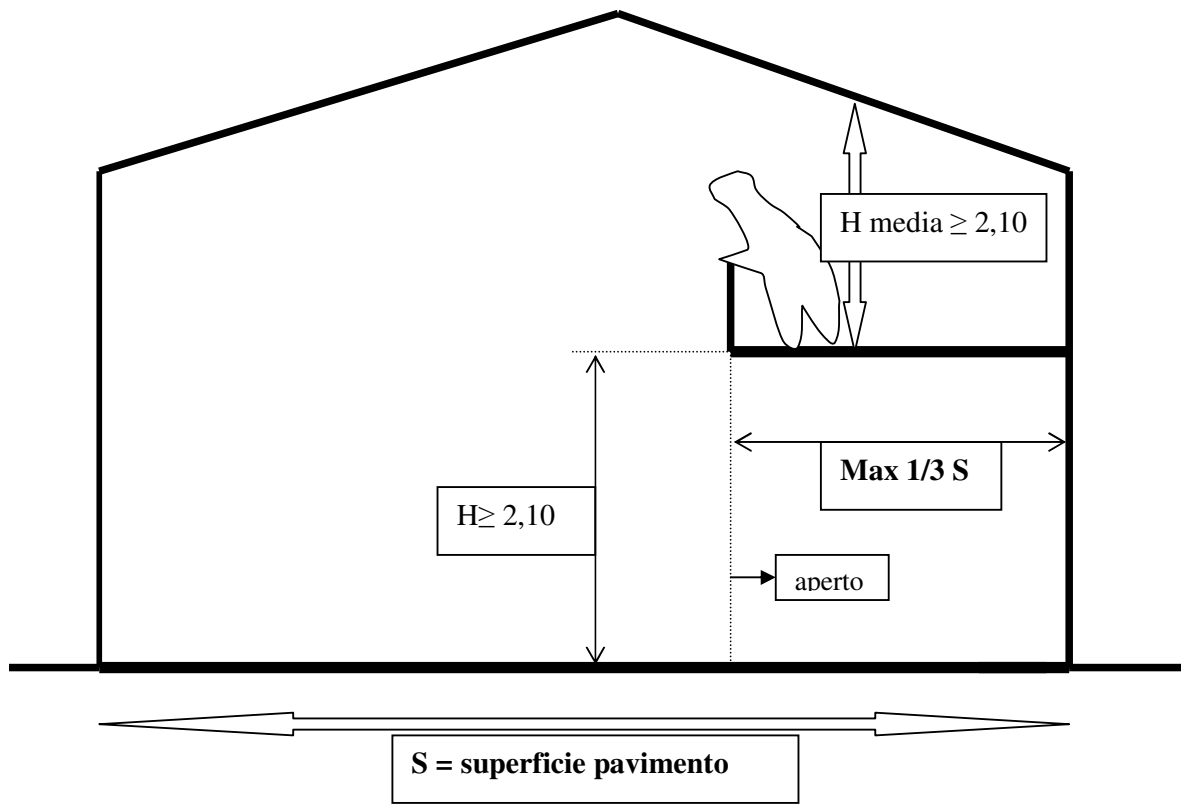

Figura 6 – CALCOLO DELLA DISTANZA PER EDIFICI O PARTI DI EDIFICI EMERGENTI DAL TERRENO Art. 7 comma 2

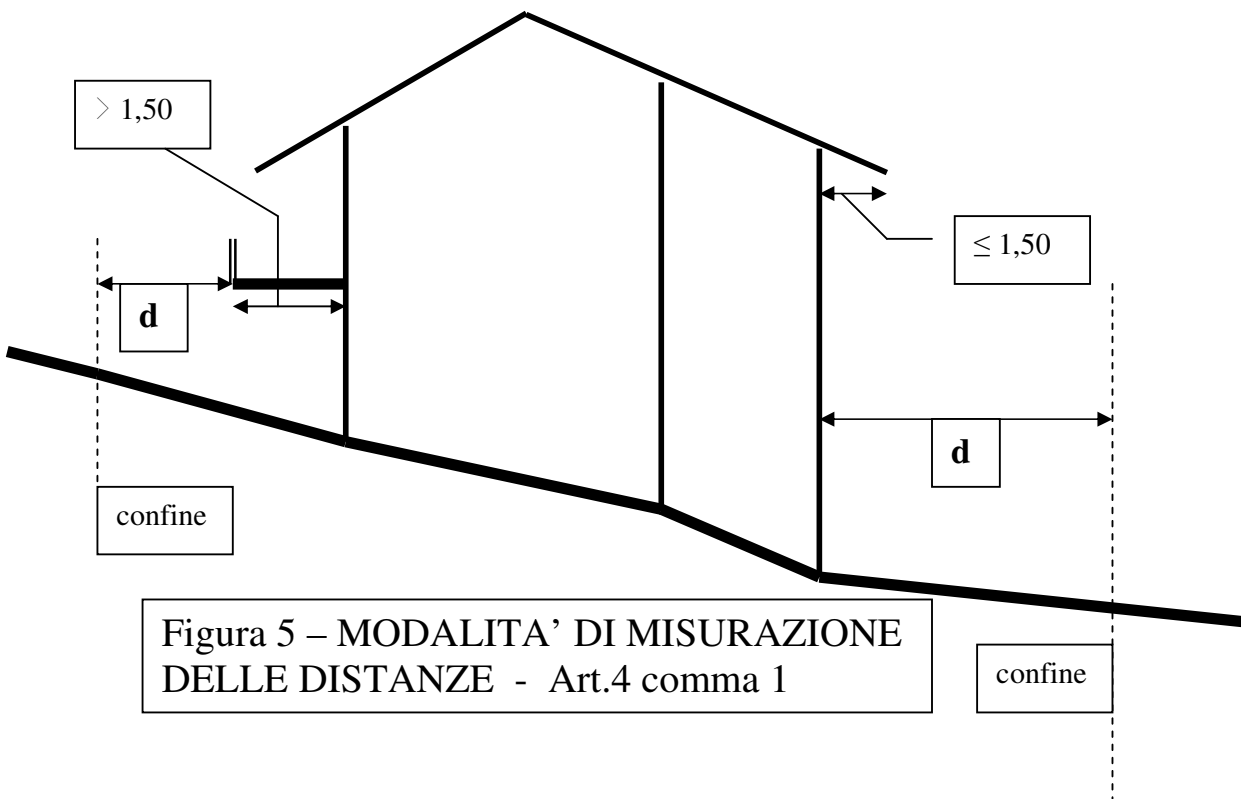
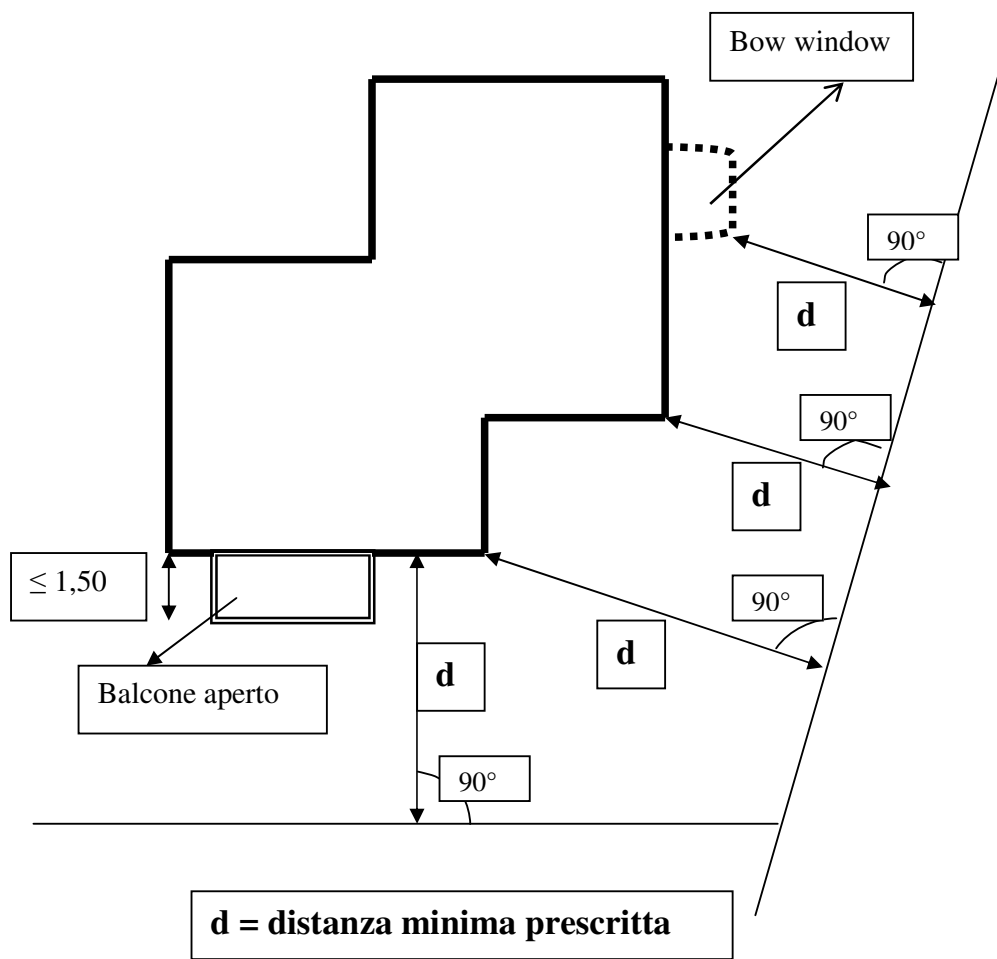

Figura 7 – ESEMPI DI APPLICAZIONE DELLA VISUALE LIBERA – Art. 7 comma 5

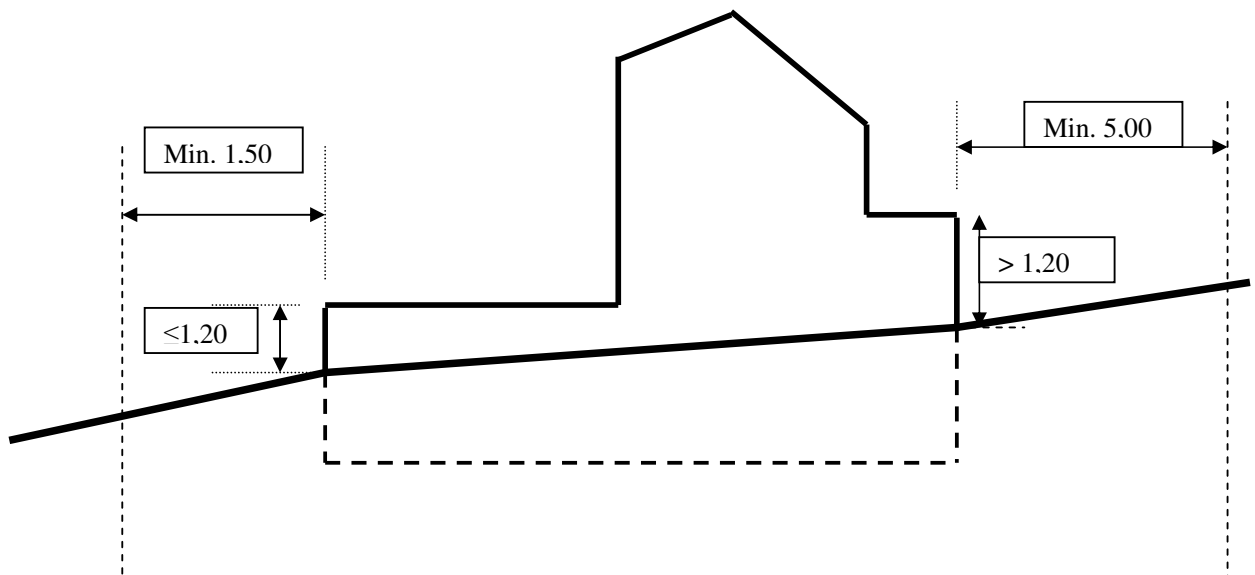

Figura 7 bis – ESEMPI DI APPLICAZIONE
DELLA VISUALE LIBERA - Art.7 comma 5 lettera c

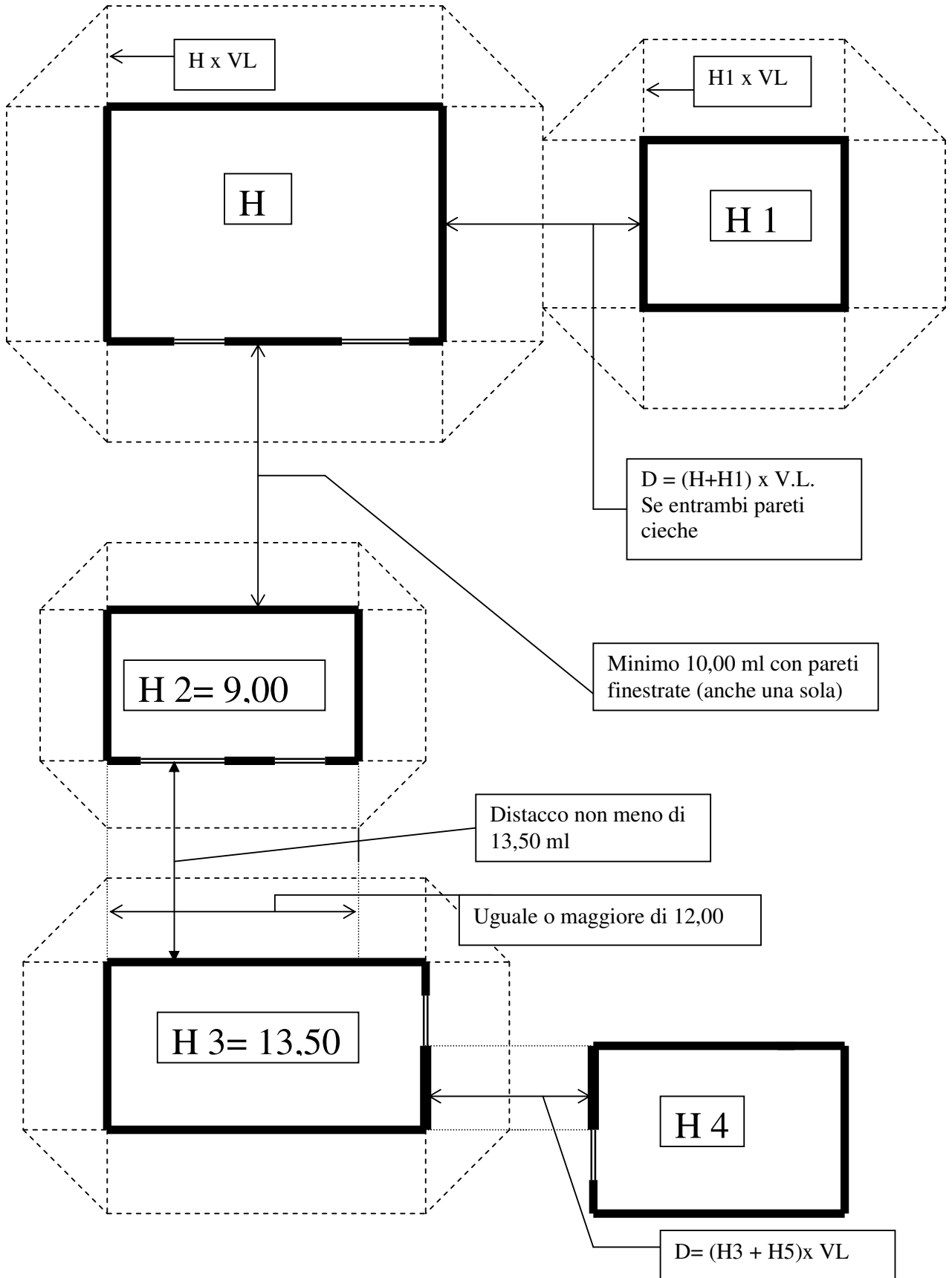

Figura 8 – ALTEZZA DEI LOCALI E DEI PIANI
Art. 3 comma 1, 2

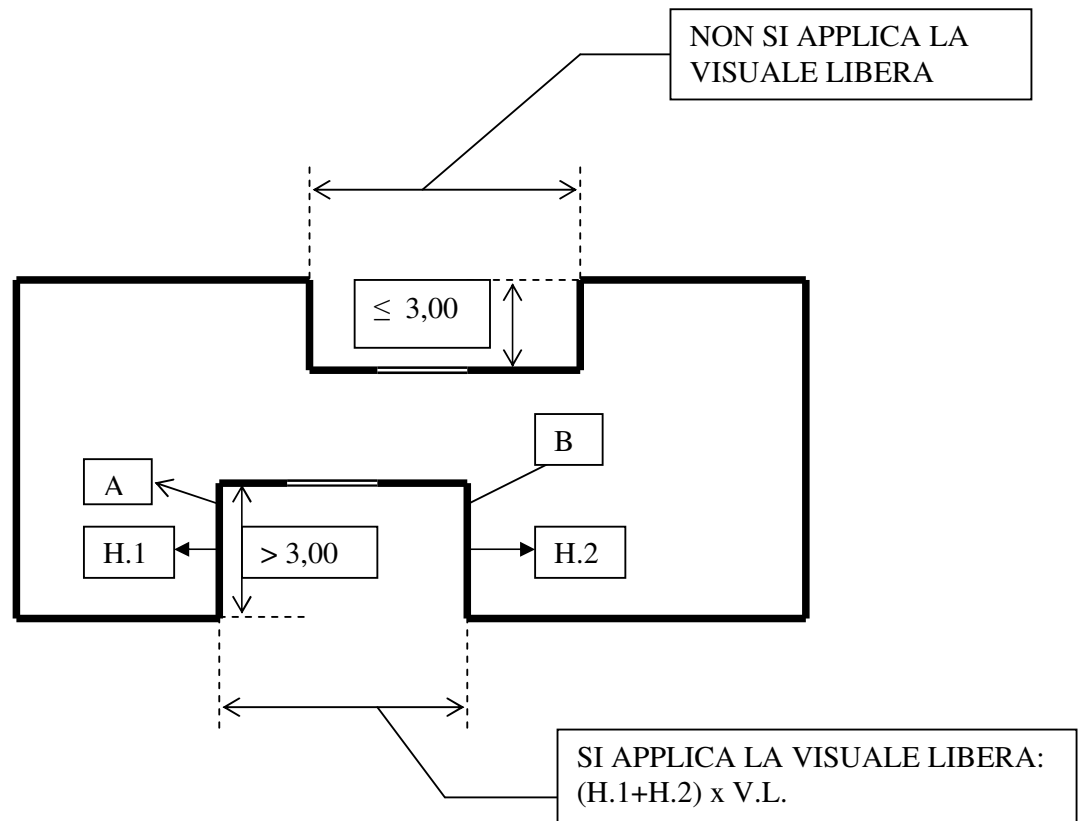

Figura 9 - MISURAZIONE DELLE ALTEZZE DEGLI EDIFICI - Art. 3 comma 3

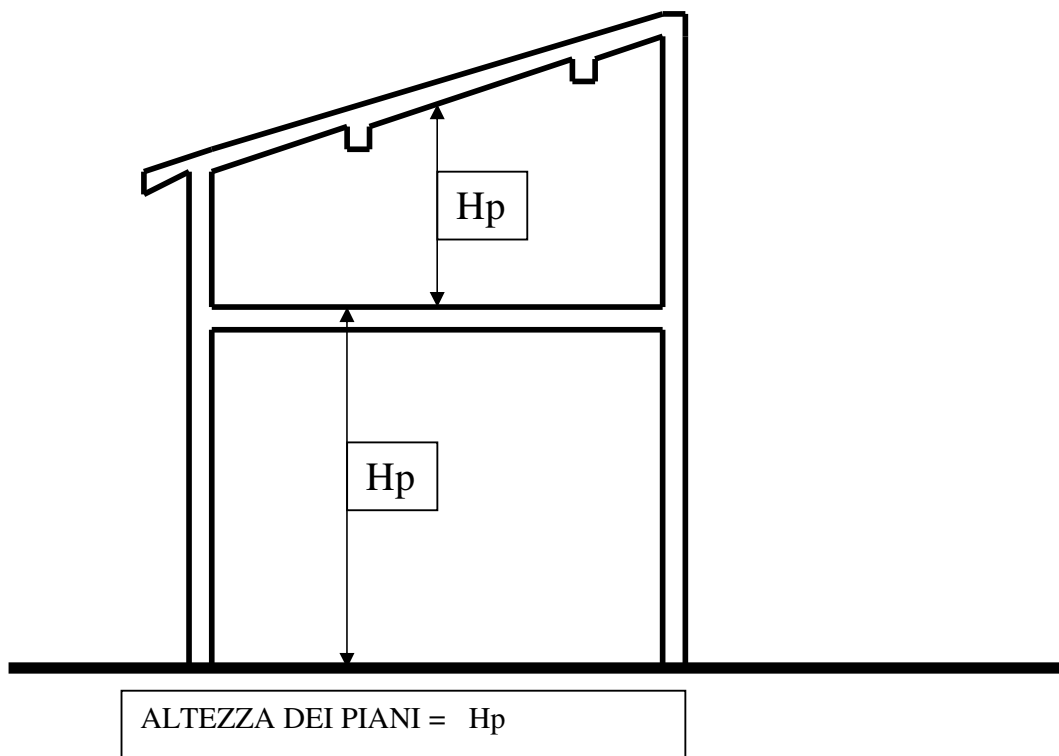
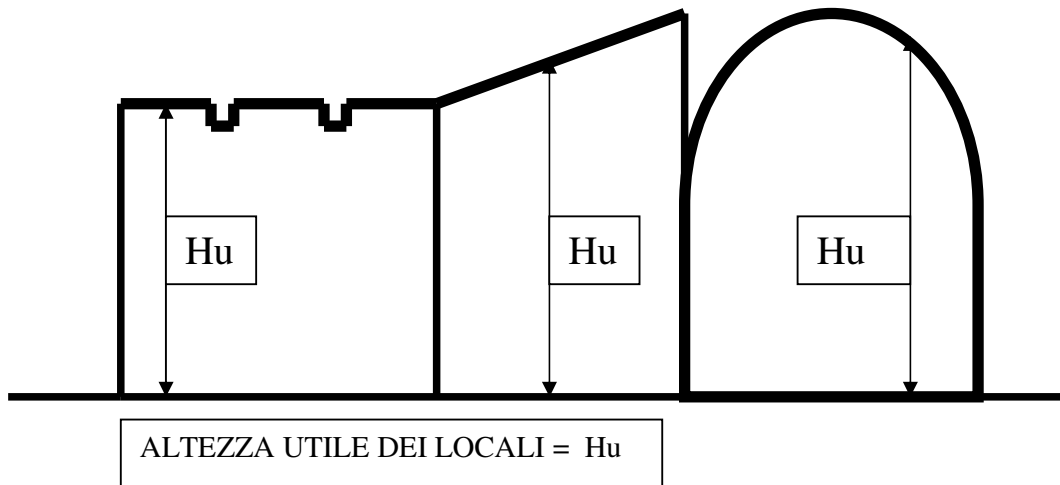

Figura 10 – CALCOLO DELL'ALTEZZA MEDIA PONDERATA
 DI UN FRONTE: = H_p - Art. 3 comma 3
 $H_p = (A + B + C) / d$

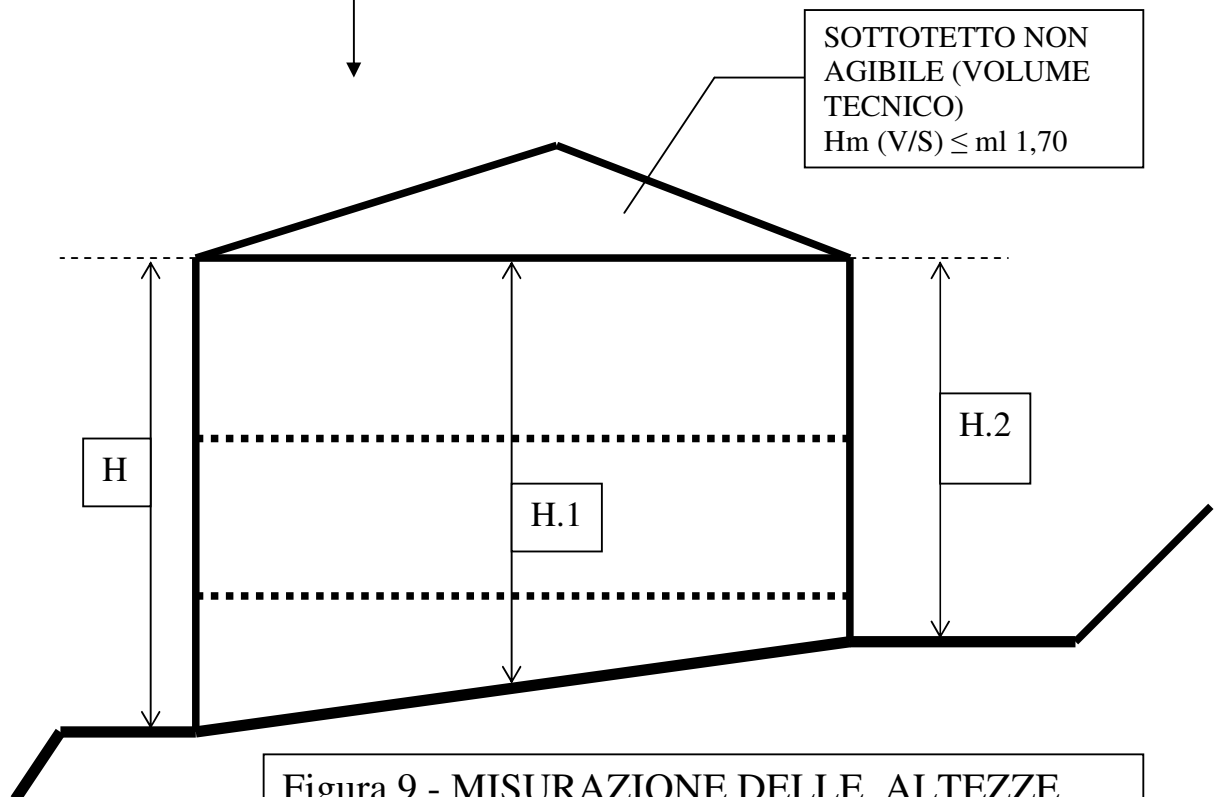
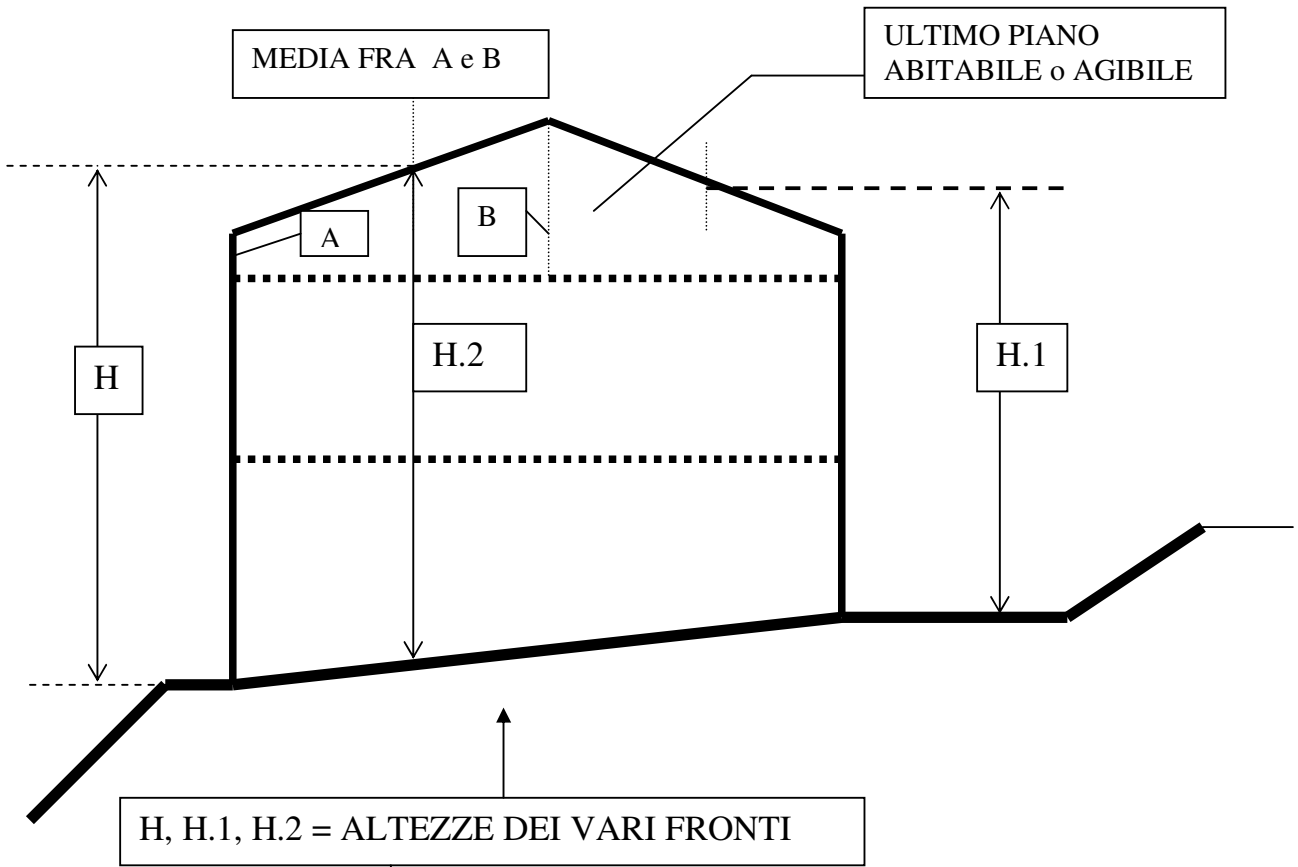

Figura 11 – INSEGNE A BANDIERA – Art. 83 comma 7

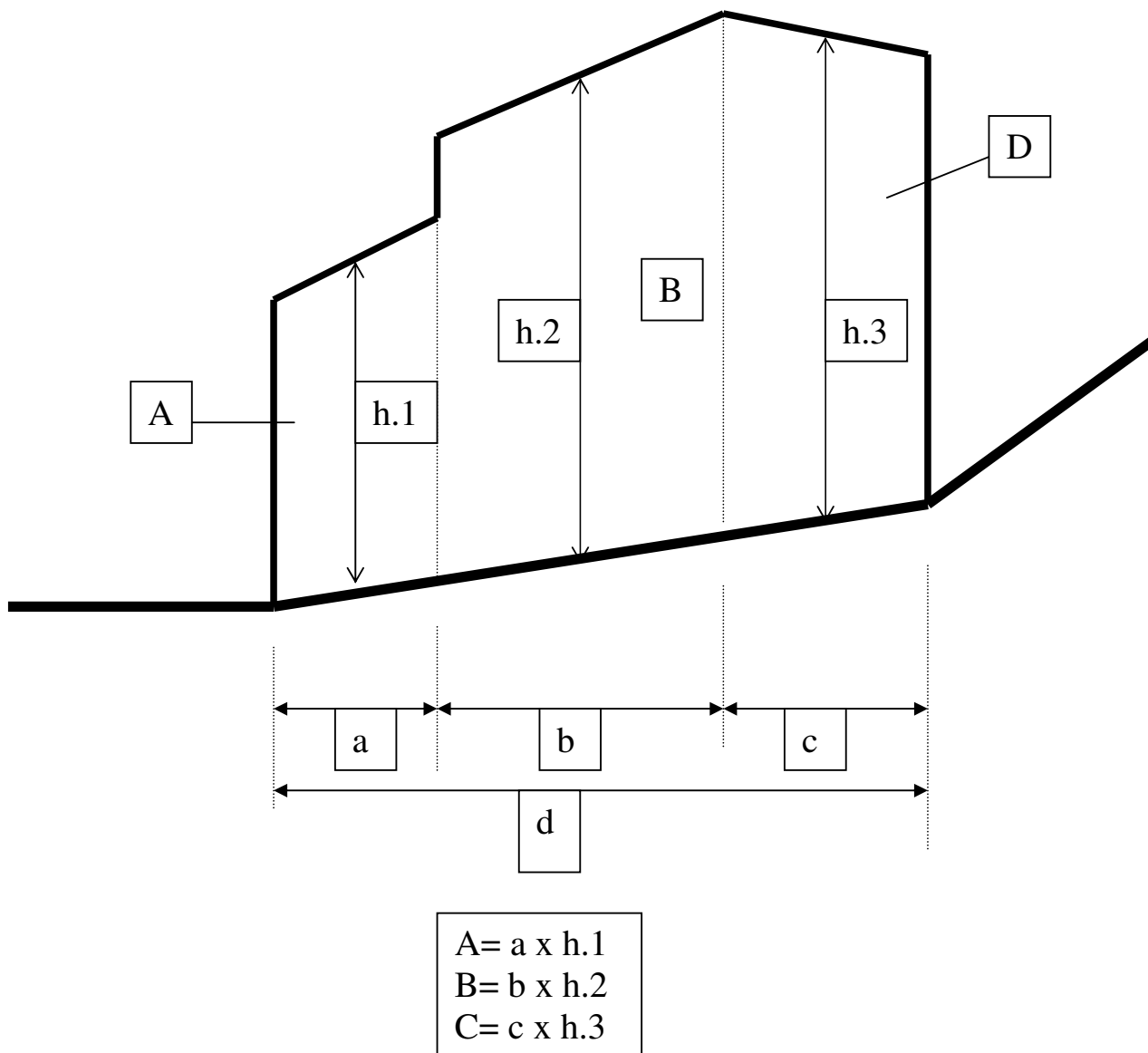

Figura 10 Bis CALCOLO DELL'ALTEZZA MEDIA PONDERATA
 DI UN FRONTE: = H_p - Art. 3 comma 3
 $H_p = (A + B) / c$

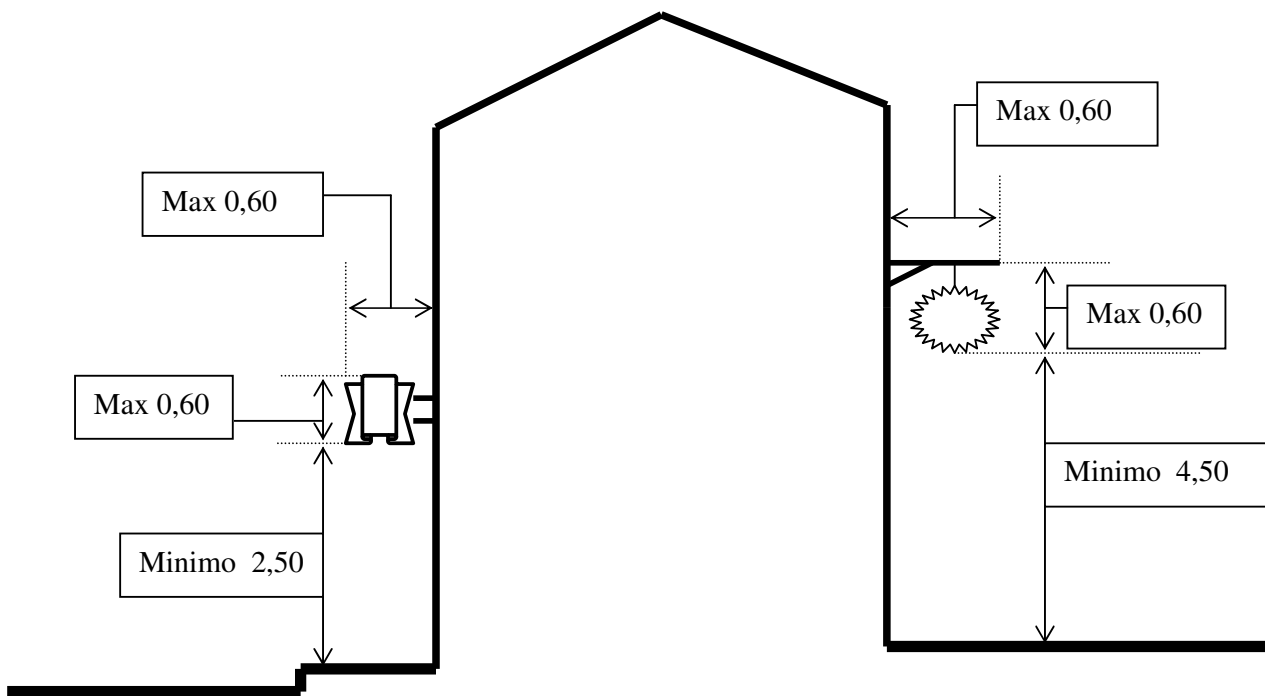
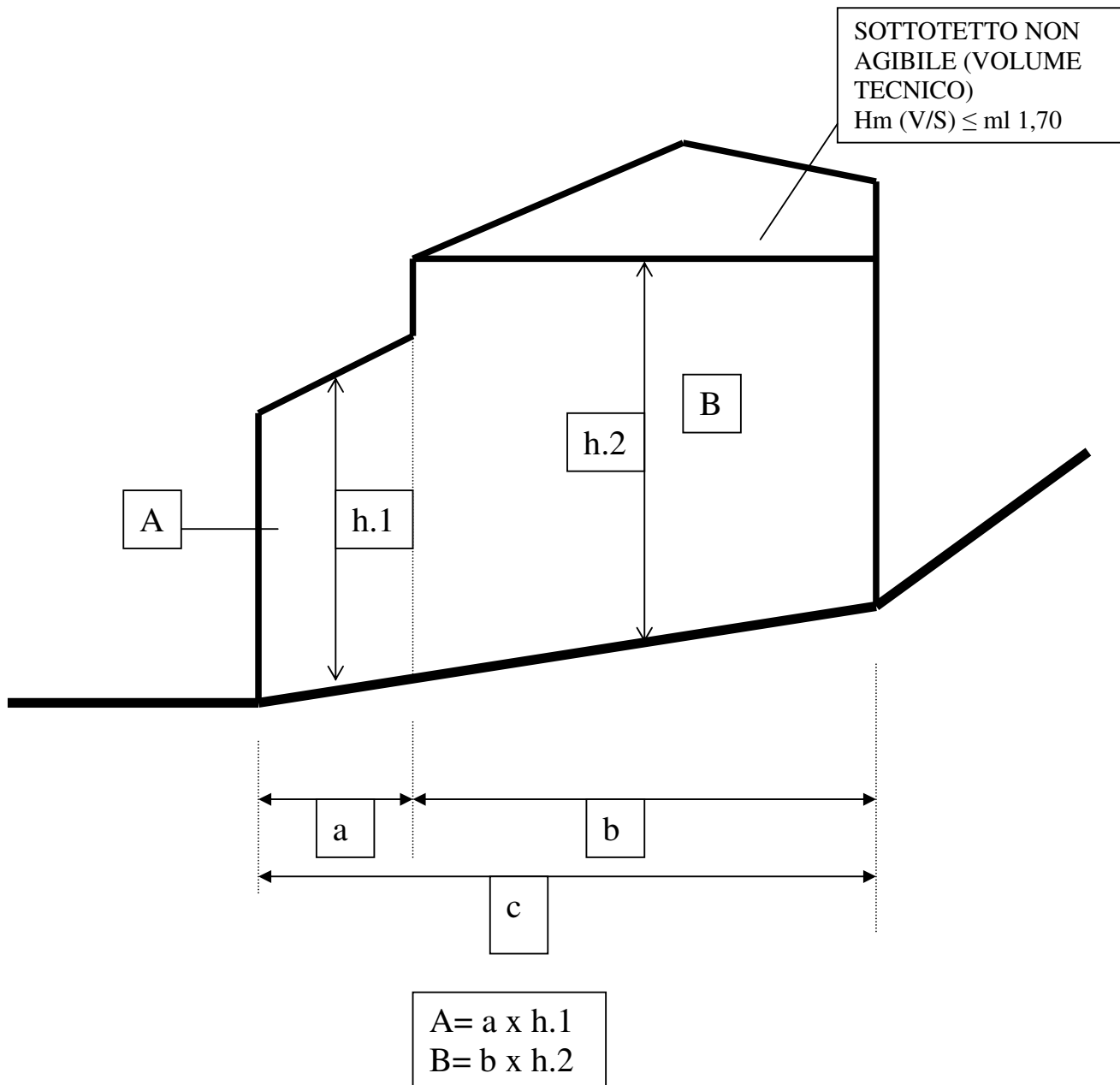